

processes

process

- a program in execution (running) on a computer
- characterized by...
 - at least one execution thread
 - an associated set of system resources
 - a current state of CPU (and possibly other resources)

threads

- the entity that can be assigned to, and executed on, a processor
 - it is meaningful only within a process
 - described by
 - the value of the program counter
 - the value of the CPU registers
- in modern operating systems a process may contains one or more thread
- we assume it contains one thread
 - unless otherwise specified

summary

- OS – process interaction
 - the point of view of the process
 - the point of view of the OS
- system calls
- process lifecycle
- state diagrams for processes
- representation within OS

the point of view of the process

- it explicitly interacts with OS by means of *system calls (syscalls)*
- like procedure calls but...
 - *syscall are made available by OS*
 - *can perform privileged operations*
- *syscalls are not called using regular “call” instructions*
 - *special instruction*
 - *software interrupt*

OS and processes interaction

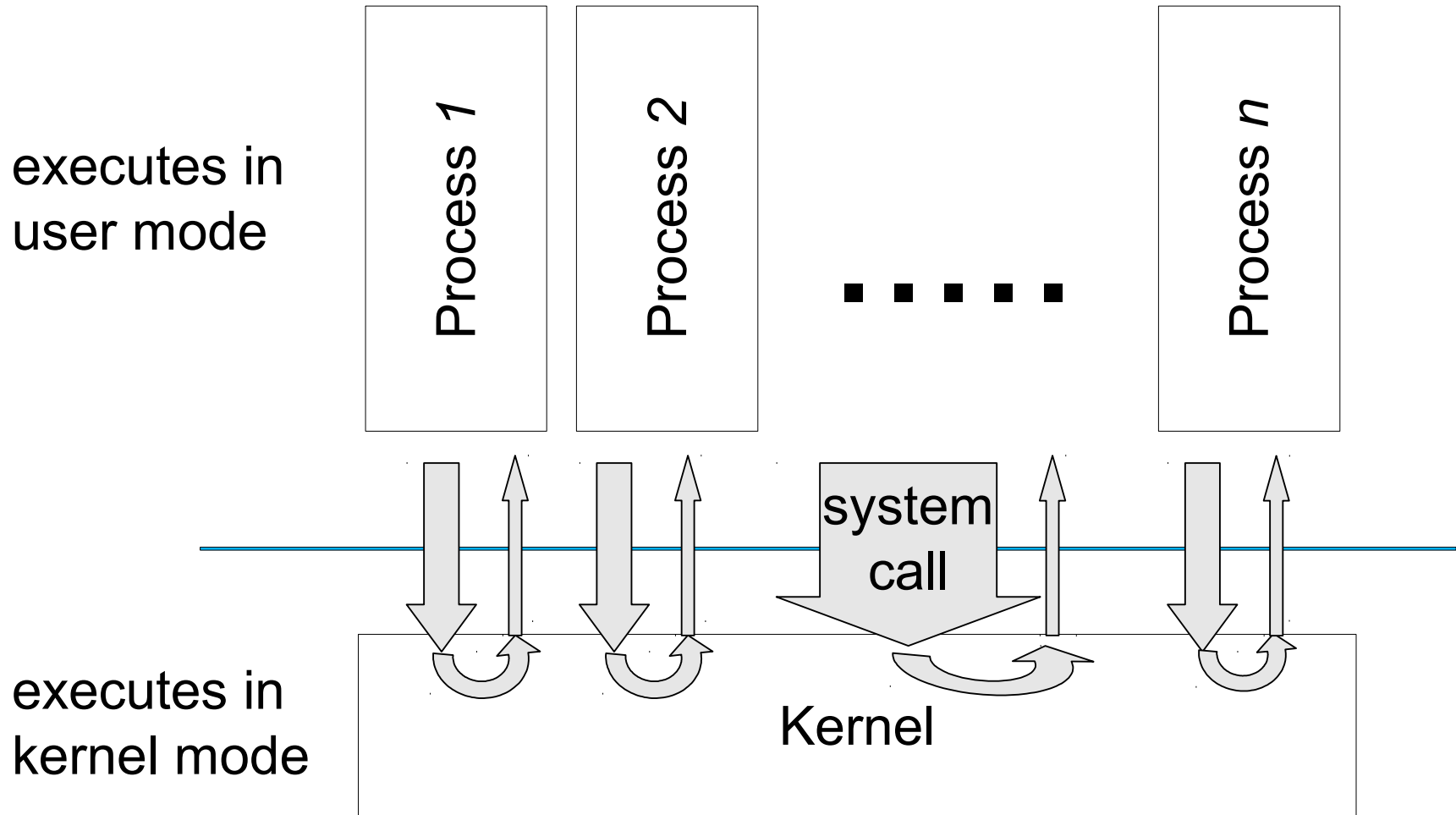



classes of syscalls

- I/O
 - read and write (need a communication channel)
- resources allocation/deallocation
 - communication channels (with i/o devices or other processes)
 - memory
 - etc.
- processes control
 - create, kill, wait for..., stop, continue, debug, etc.
- resource management (i.e. miscellanea)
 - change attributes (for files, devices, comm. channels, etc.)
 - set system values (sys. clock, routing table, ecc.)

the point of view of the OS

- when a syscall is executed, OS can...
 - ... **immediately doing** what it is asked for and returning to process execution
 - ... **postpone** the request and blocking the process until the request can be fulfilled
 - e.g. a read syscall may require a disk operation, so read cannot be immediately fulfilled

the point of view of the OS

- often more processes can be executed
 - but cpu is only one (or are limited in number)
- OS can interleave the execution of multiple processes
- OS can choose which one to run
 - maximize processor utilization
 - providing reasonable response time
- decisions are taken by the “**short time cpu scheduler**”

a model of process lifecycle

- **creation**
 - why and how a process is created?
- **execution**
 - regular “unprivileged” computation
 - syscalls (possibly blocking)
- **termination**
 - regular (it asks the OS to terminate)
 - error (illegal instruction, div. by zero, ecc.)

Process Creation

Table 3.1 Reasons for Process Creation

New batch job	The operating system is provided with a batch job control stream, usually on tape or disk. When the operating system is prepared to take on new work, it will read the next sequence of job control commands.
Interactive logon	A user at a terminal logs on to the system.
Created by OS to provide a service	The operating system can create a process to perform a function on behalf of a user program, without the user having to wait (e.g., a process to control printing).
Spawned by existing process	For purposes of modularity or to exploit parallelism, a user program can dictate the creation of a number of processes.

process creation

- but...
- in modern operating systems all causes are implemented by

process spawning

- but for the first process!
 - it is created at boot time and never dies (usually)

processes tree

- every process has a parent
 - the one that asked for its creation
- but for the first process
 - which is the root of the tree

Process Termination

Normal completion	The process executes an OS service call to indicate that it has completed running.
Time limit exceeded	The process has run longer than the specified total time limit. There are a number of possibilities for the type of time that is measured. These include total elapsed time ("wall clock time"), amount of time spent executing, and, in the case of an interactive process, the amount of time since the user last provided any input.
Memory unavailable	The process requires more memory than the system can provide.
Bounds violation	The process tries to access a memory location that it is not allowed to access.
Protection error	The process attempts to use a resource such as a file that it is not allowed to use, or it tries to use it in an improper fashion, such as writing to a read-only file.
Arithmetic error	The process tries a prohibited computation, such as division by zero, or tries to store numbers larger than the hardware can accommodate.

Process Termination

Time overrun	The process has waited longer than a specified maximum for a certain event to occur.
I/O failure	An error occurs during input or output, such as inability to find a file, failure to read or write after a specified maximum number of tries (when, for example, a defective area is encountered on a tape), or invalid operation (such as reading from the line printer).
Invalid instruction	The process attempts to execute a nonexistent instruction (often a result of branching into a data area and attempting to execute the data).
Privileged instruction	The process attempts to use an instruction reserved for the operating system.
Data misuse	A piece of data is of the wrong type or is not initialized.
Operator or OS intervention	For some reason, the operator or the operating system has terminated the process (for example, if a deadlock exists).
Parent termination	When a parent terminates, the operating system may automatically terminate all of the offspring of that parent.
Parent request	A parent process typically has the authority to terminate any of its offspring.

process termination

- normal completion is asked by a process by calling a specific syscall
- other form of termination when something wrong is detected...
 - during the execution of a syscall
 - of the process (e.g. memory unavailable)
 - of other processes (e.g. regular termination of A implies killing child B)
 - during handling of an interrupt
 - e.g. div. by zero, illegal instruction, illegal memory access, etc.

scheduling and dispatching

- scheduling
 - deciding which is the next process executed by the CPU
- dispatching
 - setting up CPU registers to execute the process
 - i.e. restore the context for the process

scheduler vs. dispatcher

- scheduling and dispatching are usually performed together by the same routine
- we use “scheduler” or “dispatcher” depending on the aspect we need to emphasize

dispatching example

- what instructions are executed by the cpu?

Processes and Memory

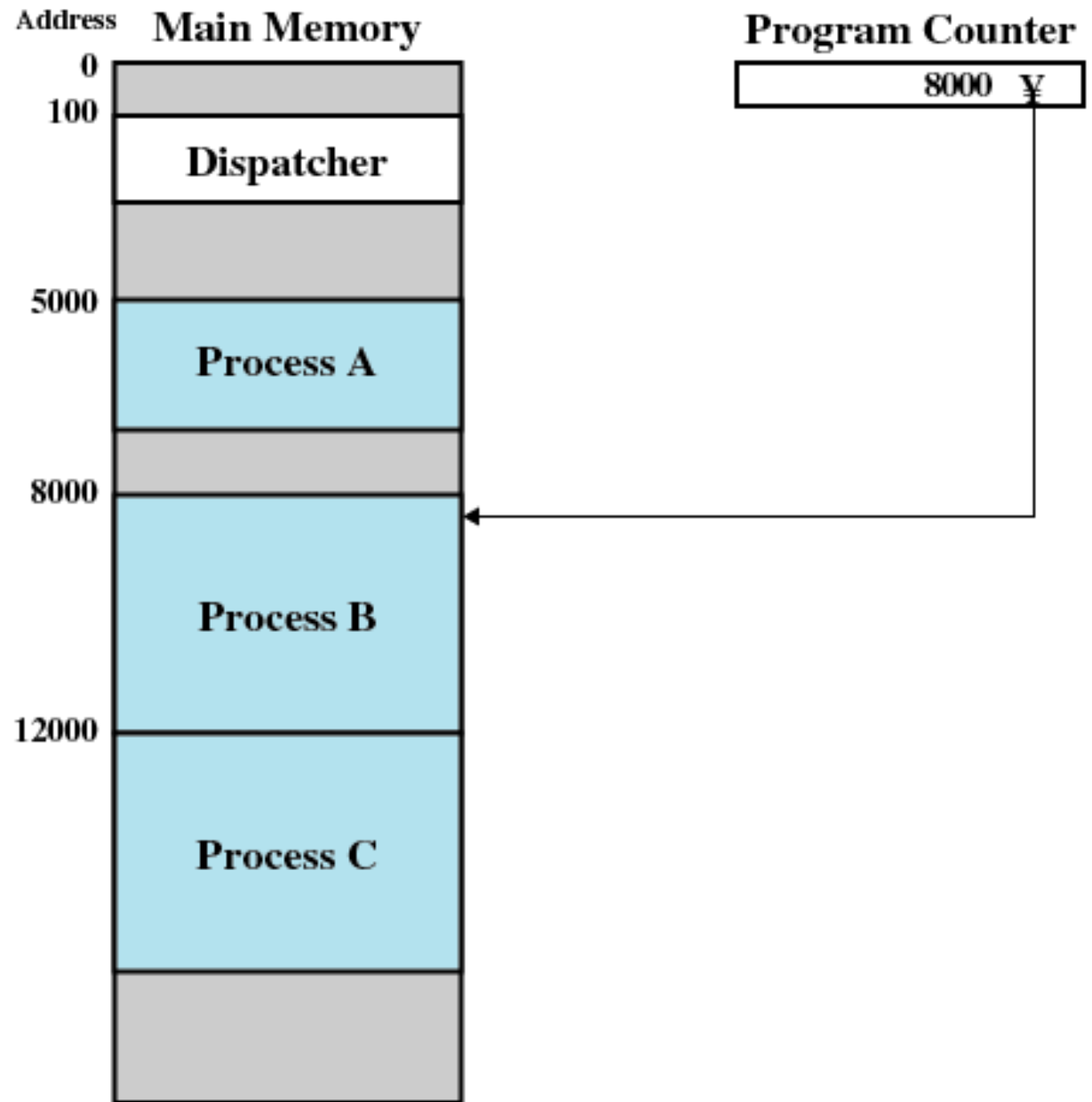

Trace of Process

- Sequence of instruction (addresses) for each process

5000	8000	12000
5001	8001	12001
5002	8002	12002
5003	8003	12003
5004		12004
5005		12005
5006		12006
5007		12007
5008		12008
5009		12009
5010		12010
5011		12011
(a) Trace of Process A	(b) Trace of Process B	(c) Trace of Process C

5000 = Starting address of program of Process A

8000 = Starting address of program of Process B

12000 = Starting address of program of Process C

Dispatcher

- The *dispatcher* switches the processor from one process to another (**process switch**)

1	5000		
2	5001		
3	5002		
4	5003		
5	5004		
6	5005		
-----Time out			
7	100		
8	101		
9	102		
10	103		
11	104		
12	105		
13	8000		
14	8001		
15	8002		
16	8003		
-----I/O request			
17	100		
18	101		
19	102		
20	103		
21	104		
22	105		
23	12000		
24	12001		
25	12002		
26	12003		
27	12004		
28	12005		
-----Time out			
29	100		
30	101		
31	102		
32	103		
33	104		
34	105		
35	5006		
36	5007		
37	5008		
38	5009		
39	5010		
40	5011		
-----Time out			
41	100		
42	101		
43	102		
44	103		
45	104		
46	105		
47	12006		
48	12007		
49	12008		
50	12009		
51	12010		
52	12011		
-----Time out			

100 = Starting address of dispatcher program

shaded areas indicate execution of dispatcher process;
 first and third columns count instruction cycles;
 second and fourth columns show address of instruction being executed

Two-State Process Model

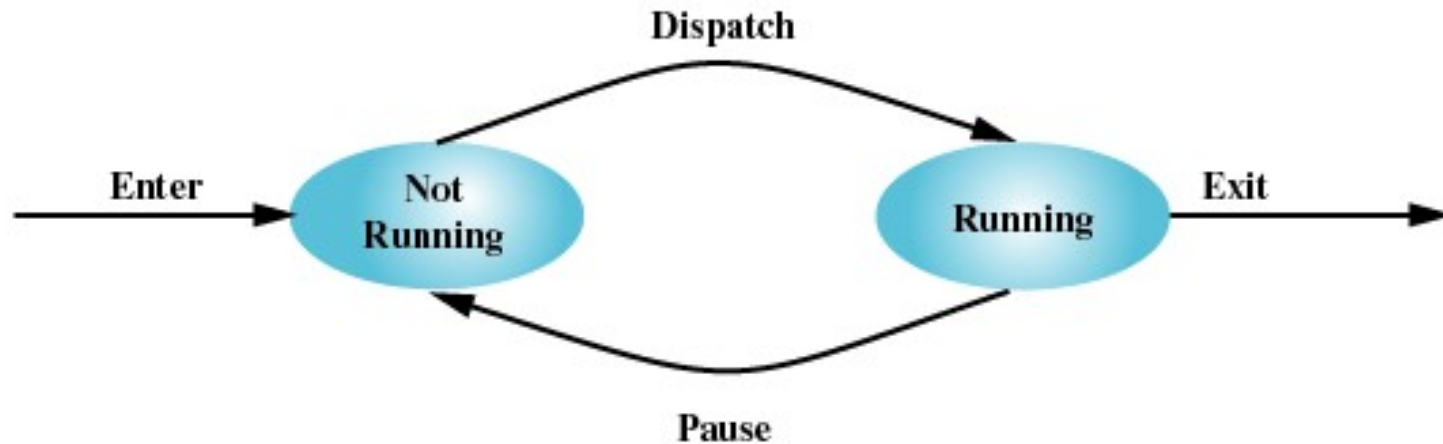

(a) State transition diagram

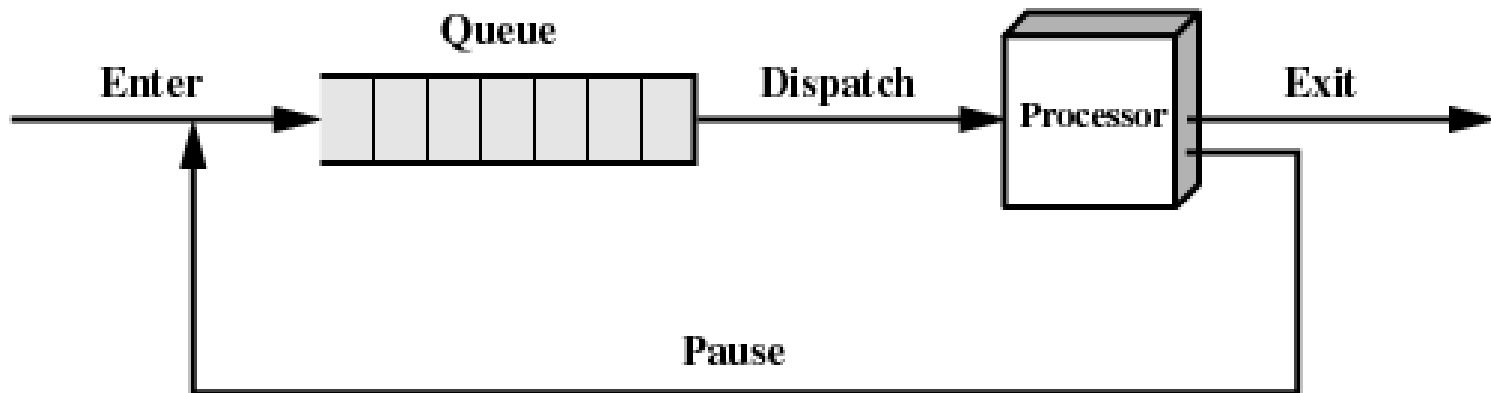

(b) Queuing diagram

Five-State Process Model

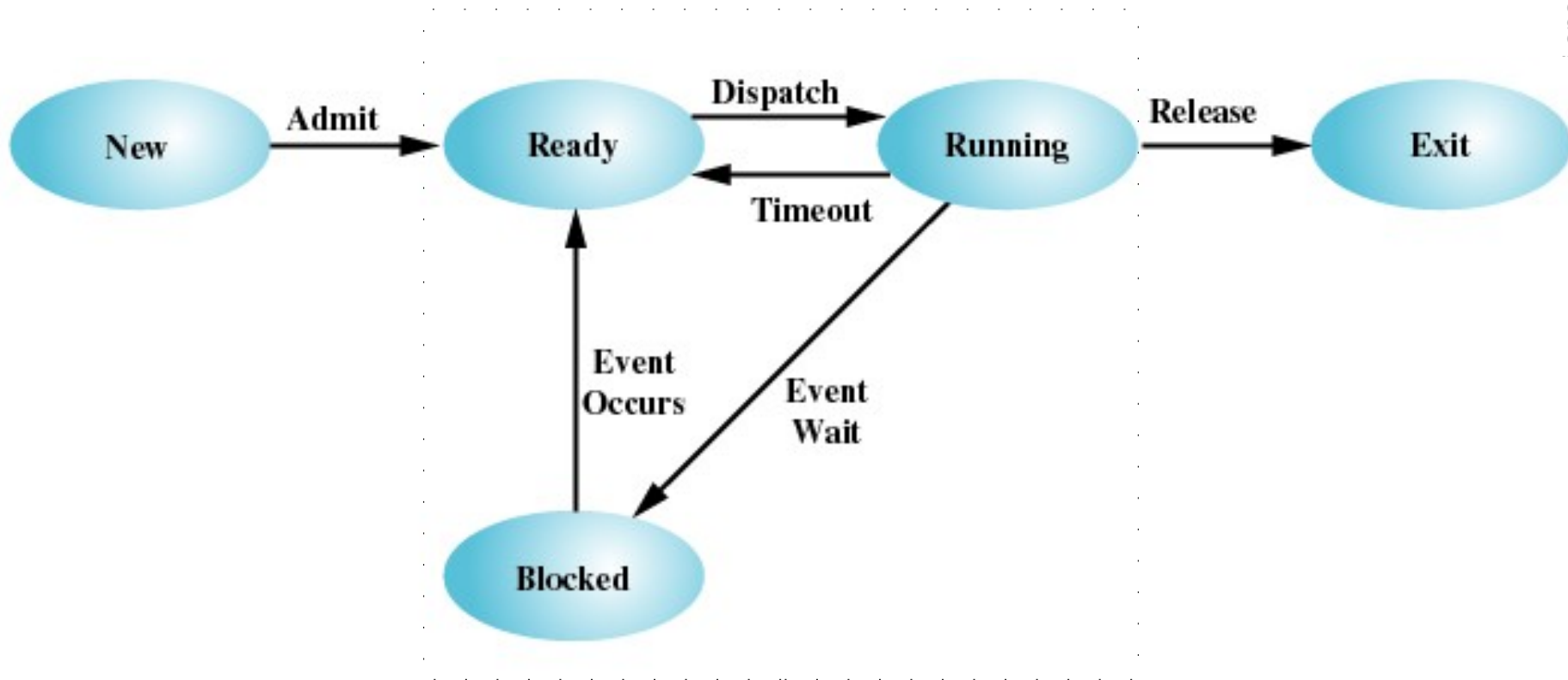

Figure 3.6 Five-State Process Model

Process States

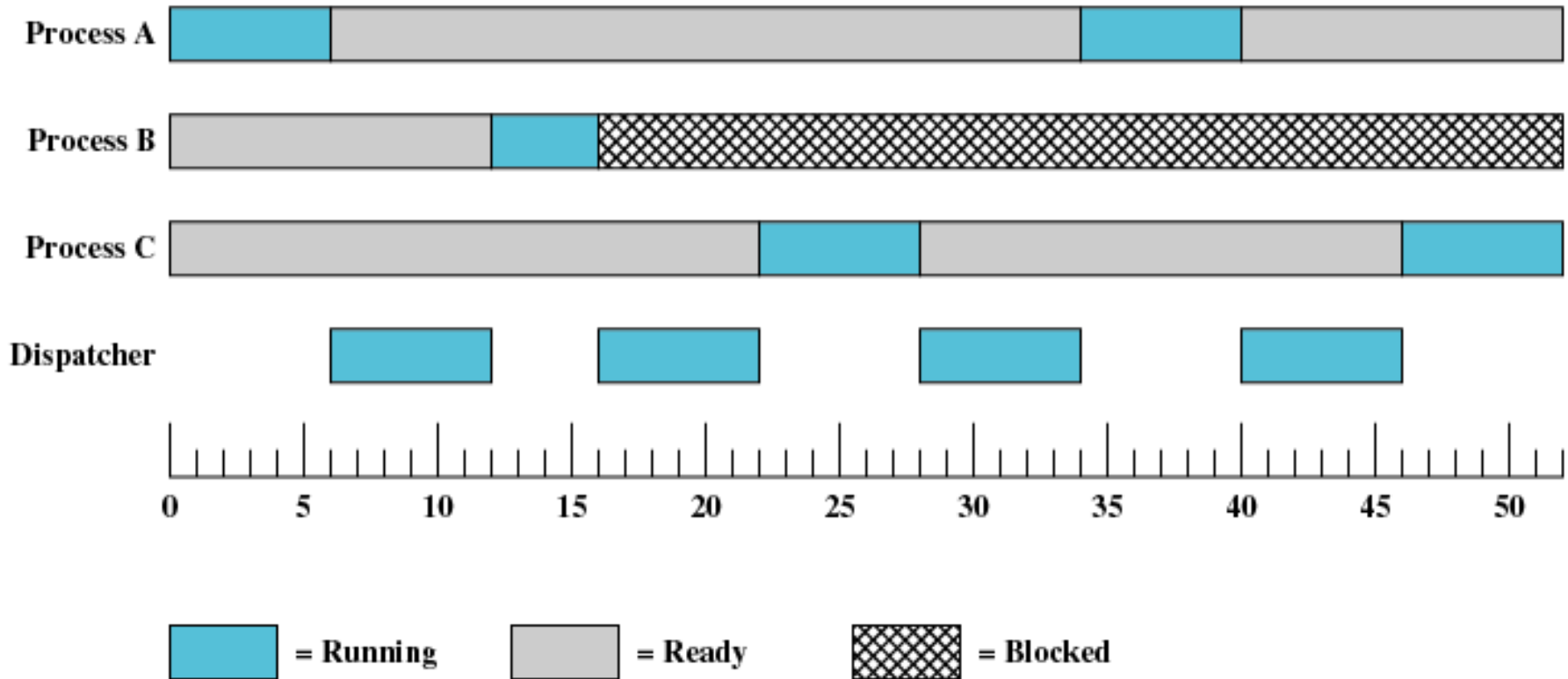
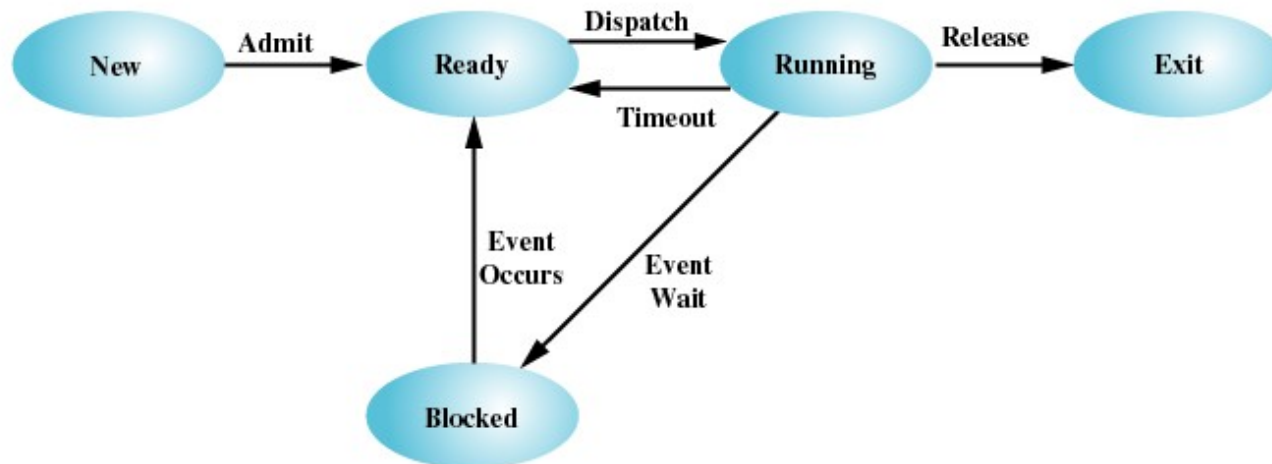
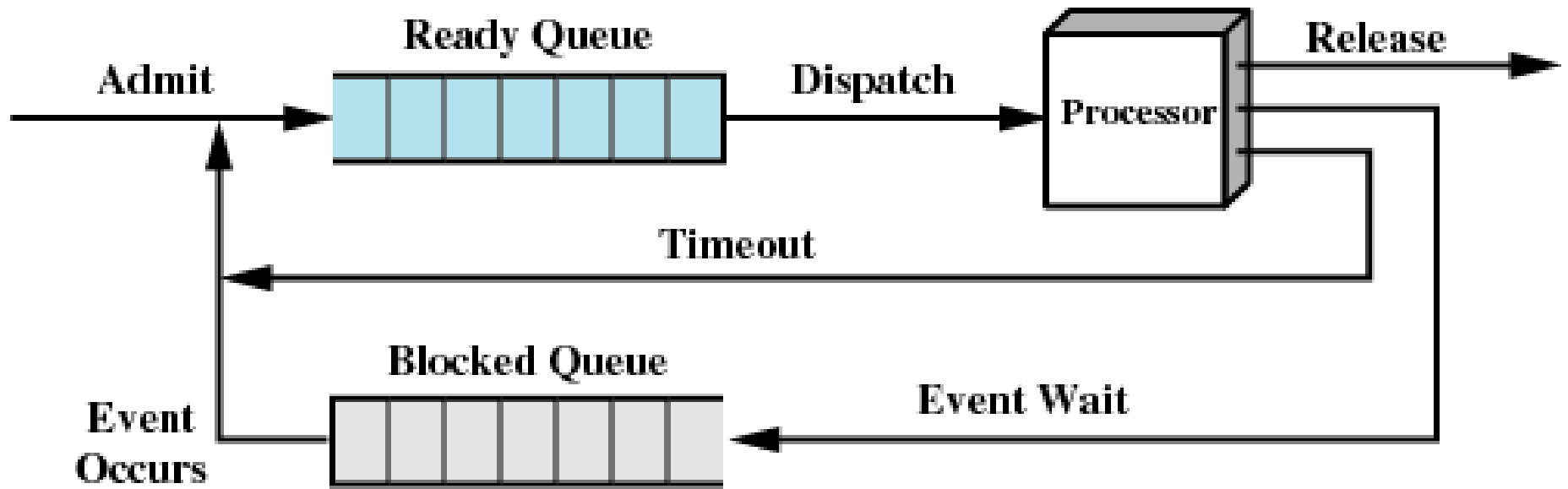
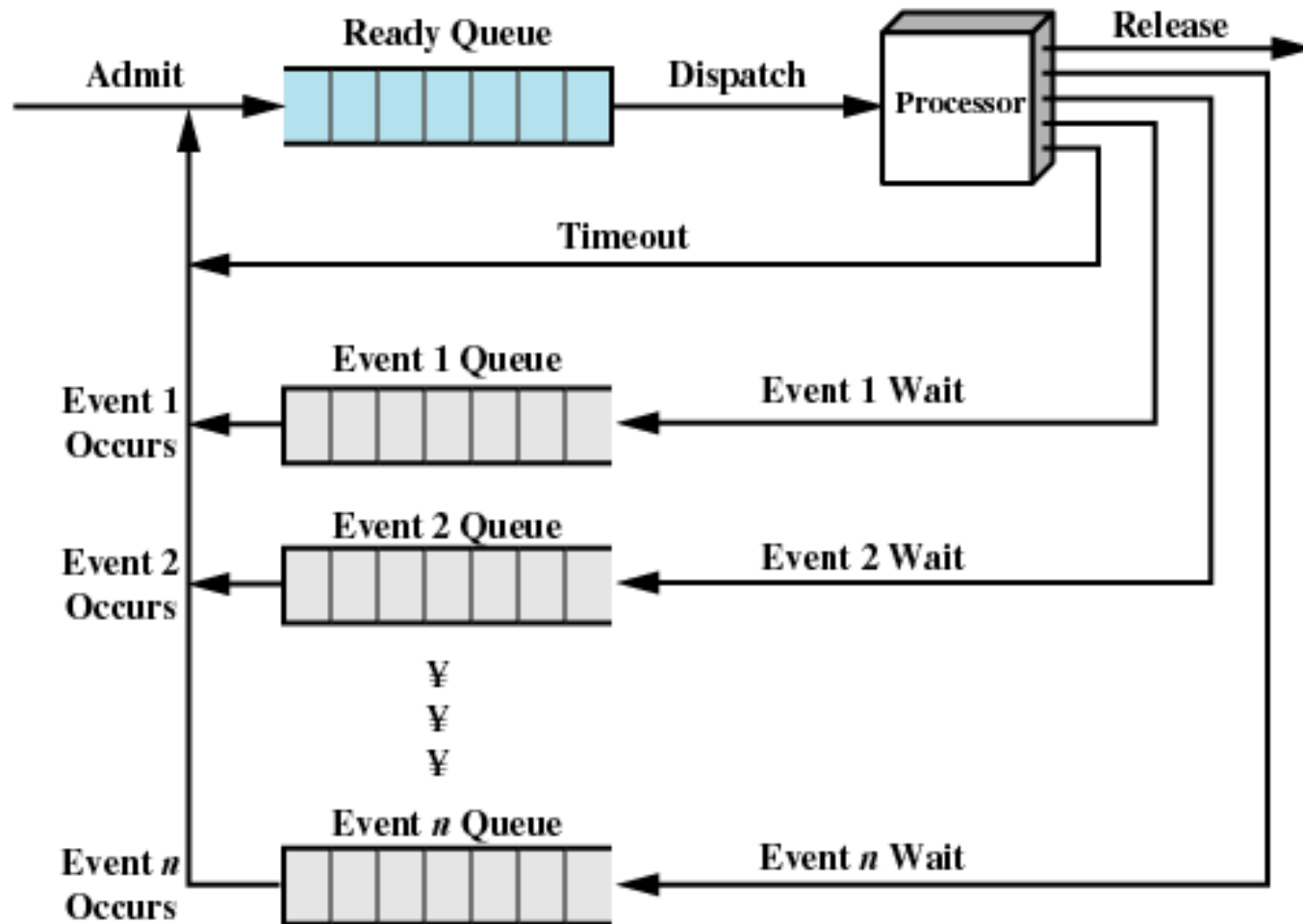

Figure 3.7 Process States for Trace of Figure 3.4

One sequential I/O device



Many sequential I/O devices



(b) Multiple blocked queues

Suspended Processes

- Processor is faster than I/O so many processes could be waiting for I/O
- Swap these processes to disk to free up memory
- Blocked state becomes suspend state when swapped to disk
- Two new states
 - Blocked/Suspend
 - Ready/Suspend

Two New States

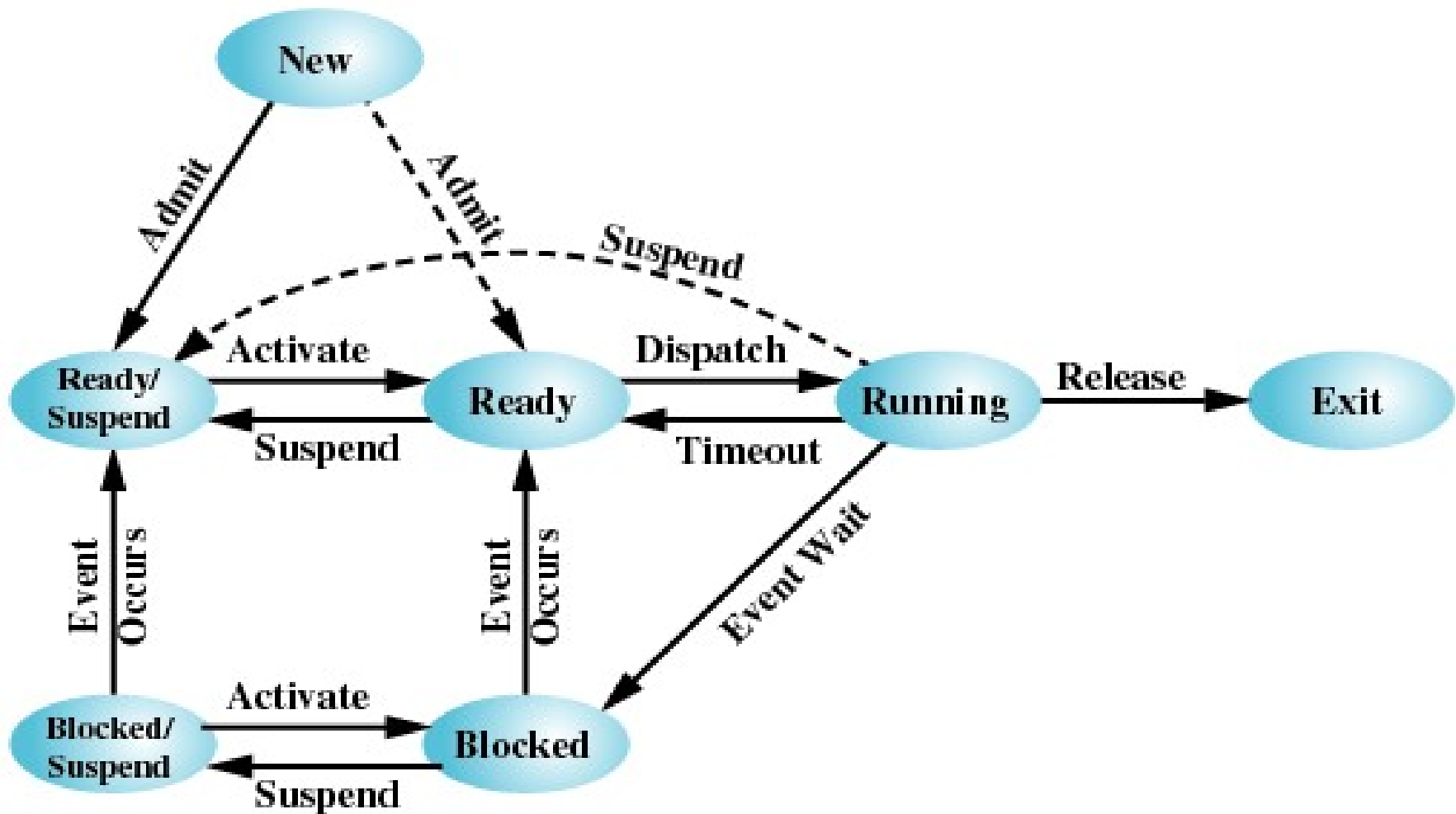

(b) With Two Suspend States

Several Reasons for Process Suspension

Swapping

The operating system needs to release sufficient main memory to bring in a process that is ready to execute.

Other OS reason

The operating system may suspend a background or utility process or a process that is suspected of causing a problem.

Interactive user request

A user may wish to suspend execution of a program for purposes of debugging or in connection with the use of a resource.

Timing

A process may be executed periodically (e.g., an accounting or system monitoring process) and may be suspended while waiting for the next time interval.

Parent process request

A parent process may wish to suspend execution of a descendent to examine or modify the suspended process, or to coordinate the activity of various descendents.

process description

Process Image

Table 3.4 Typical Elements of a Process Image

User Data

The modifiable part of the user space. May include program data, a user stack area, and programs that may be modified.

User Program

The program to be executed.

System Stack

Each process has one or more last-in-first-out (LIFO) system stacks associated with it. A stack is used to store parameters and calling addresses for procedure and system calls.

Process Control Block

Data needed by the operating system to control the process (see Table 3.5).

OS controls assignment of resources to processes

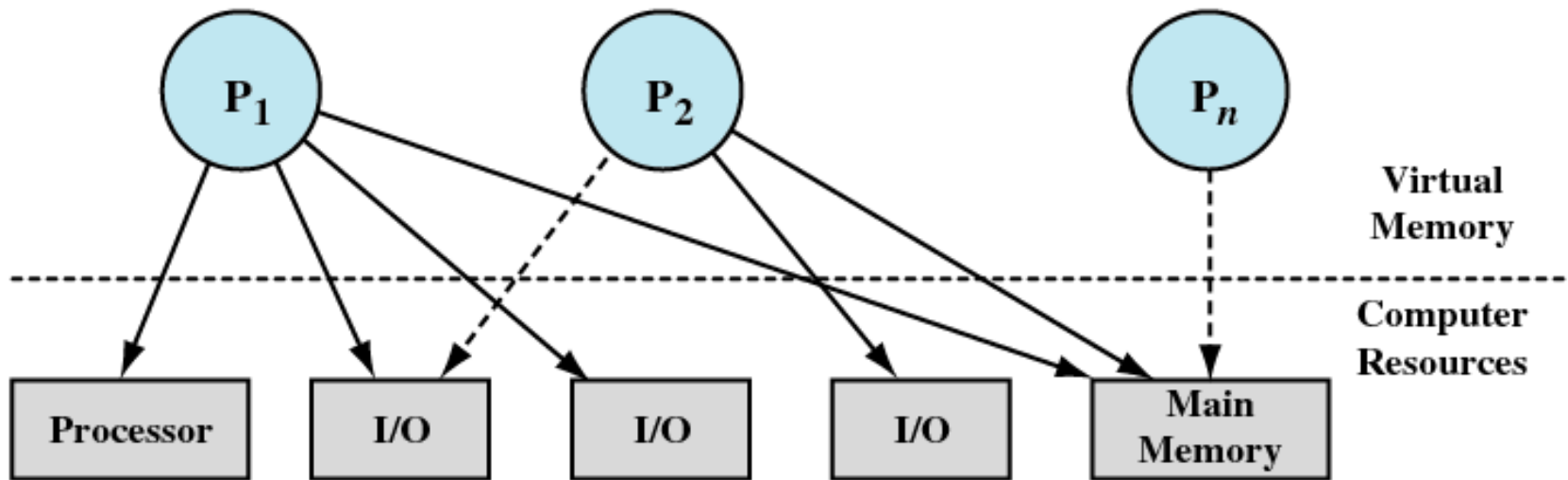

Process Control Block (PCB)

- contains data about **one** process
 - one instance for each process
- contains all the information we need to...
 - ...interrupt a running process
 - ...resume execution
- created and managed by the operating system
- allows support for multiple processes

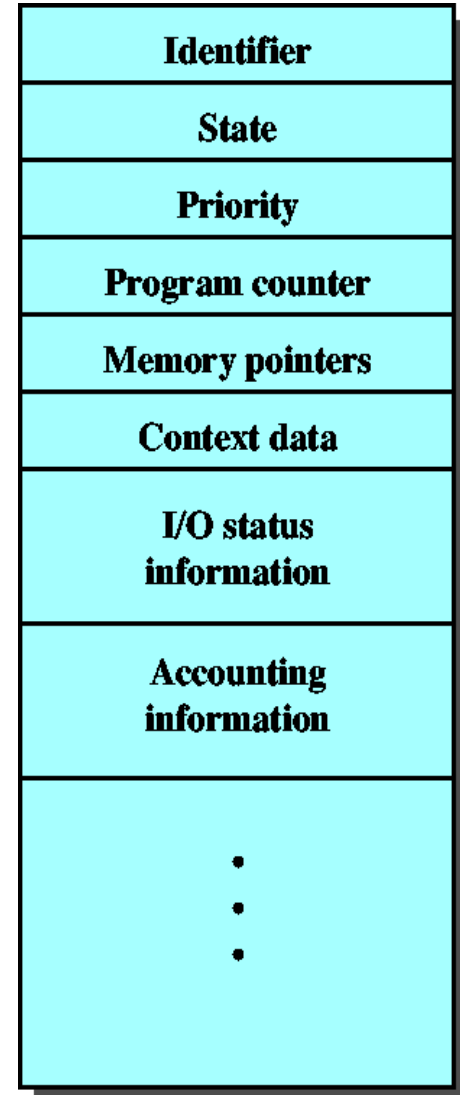

Process Elements in PCB

they largely depend on the OS

- Process Identifier (PID)
- State (ready, blocked, etc.)
 - if blocked, events the process is waiting for
- Priority (for the scheduler)
- saved CPU registers and PC (a.k.a. context)
- Memory pointers (program, data, stack, tables, etc.)
- I/O status information (open files, outstanding I/O requests, inter-processes communication, etc)
- Accounting information (CPU time used, limits, etc.)
- user that owns the process, and/or privileges
- process that created the process

Data Structuring

- PCB – PCB pointers
 - parent-child (creator-created) relationship with another process
- queues
 - all processes in a waiting state for a particular priority level may be linked in a queue.

Process Creation

- Assign a unique process identifier
- Allocate space for the process
- Initialize process control block
- Set up appropriate linkages
 - e.g. add new process to linked list used for scheduling queue
- Create or expand other data structures
 - e.g. maintain an accounting file

PCB synonyms

- process descriptor
- task control block
- task descriptor

linux

- `task_struct`

PCB related data structures

- process table
- memory tables
- I/O tables
- file tables

Process Table

- one entry for each process
- contains a minimal amount of information needed to activate the process
 - usually a “pointer” to the PCB
 - it may be a complex data structure (tree, hash table, ecc.)

Memory Tables

- Allocation of main memory to processes
- Allocation of secondary memory to processes
- Protection attributes for access to shared memory regions
- Information needed to manage virtual memory

I/O Tables

- I/O device is available or assigned
- Status of I/O operation
- Location in main memory being used as the source or destination of the I/O transfer

File Tables

- Existence of files
- Location on secondary memory
- Current Status
- Attributes
- Sometimes this information is maintained by a file management system

process control

mode switch

- two cases
 - user-mode → kernel-mode
 - triggered by an interrupt or a system call
 - set cpu in priviledged mode
 - may save the cpu state
 - kernel-mode → user-mode
 - triggered by the kernel when it “decides” to resume process execution
 - set cpu in unpriviledged mode
 - may restore all or part of the cpu state

process switch (dispatching)

- a process switch assigns the cpu to a different process
 - before: P_1 running, P_2 ready
 - after: P_1 not running, P_2 running
- it is performed in kernel-mode
 - it requires two mode switches
 - 1 user-mode \rightarrow kernel-mode before the process switch
 - triggered by interrupt, trap or system call
 - kernel possibly fulfill a request (e.g. I/O)
 - 2 kernel-mode \rightarrow user-mode after the process switch
 - into the process chosen by the kernel (scheduler)

process switch

- it modifies OS data structures
 - set proper state in PCB of P_1 and P_2
 - update queues
 - move P_1 into the appropriate queue
 - move P_2 out of the ready queue
 - update CPU memory tables for the image of P_2
- the next mode switch (kernel-mode \rightarrow user-mode) will restore the cpu state of P_2

typical situations for switching mode and/or process

- clock interrupt
 - process has executed for the maximum allowable time slice
 - always switch process
- system call
 - process switch when it is a blocking I/O request
 - OS may check if other processes have greater priority and possibly switch process

typical situations for switching mode and maybe process

- I/O interrupt
 - a blocked process may become ready
 - process switch depends on OS policies and priorities
- other interrupts (a.k.a traps)
 - memory page fault (virtual memory)
 - current process becomes blocked (waiting for the page) and process is switched
 - error or exception
 - current process usually die and process is switched

execution of the OS

- the OS is executed by the cpu
- is the OS a process?
 - that is, when the OS is executed, the memory layout seen by the processor is that of a process?
- several architectures are possible
 - non-process kernel
 - kernel execution within user processes
 - process-based operating system

non-process kernel

- kernel is executed outside of any process
 - kernel has its own “memory space”
 - there is not a OS process anyway!
 - inefficient (memory tables reconfiguration for each mode switch)
 - kernel implements tricks to access the images of processes
 - obsolete

Execution Within User Processes

- the kernel appears in the memory layout of each process
 - shared pages
- no reconfiguration of CPU memory table is needed (efficient)
 - kernel execution need only a mode switch
 - waste of virtual address space for the kernel is negligible

Execution Within User Processes

- each process has its own **image**
- image contains also
 - kernel stack
 - kernel program
 - kernel data
- kernel program and data are shared by all images
 - kernel mode is needed to read and write them

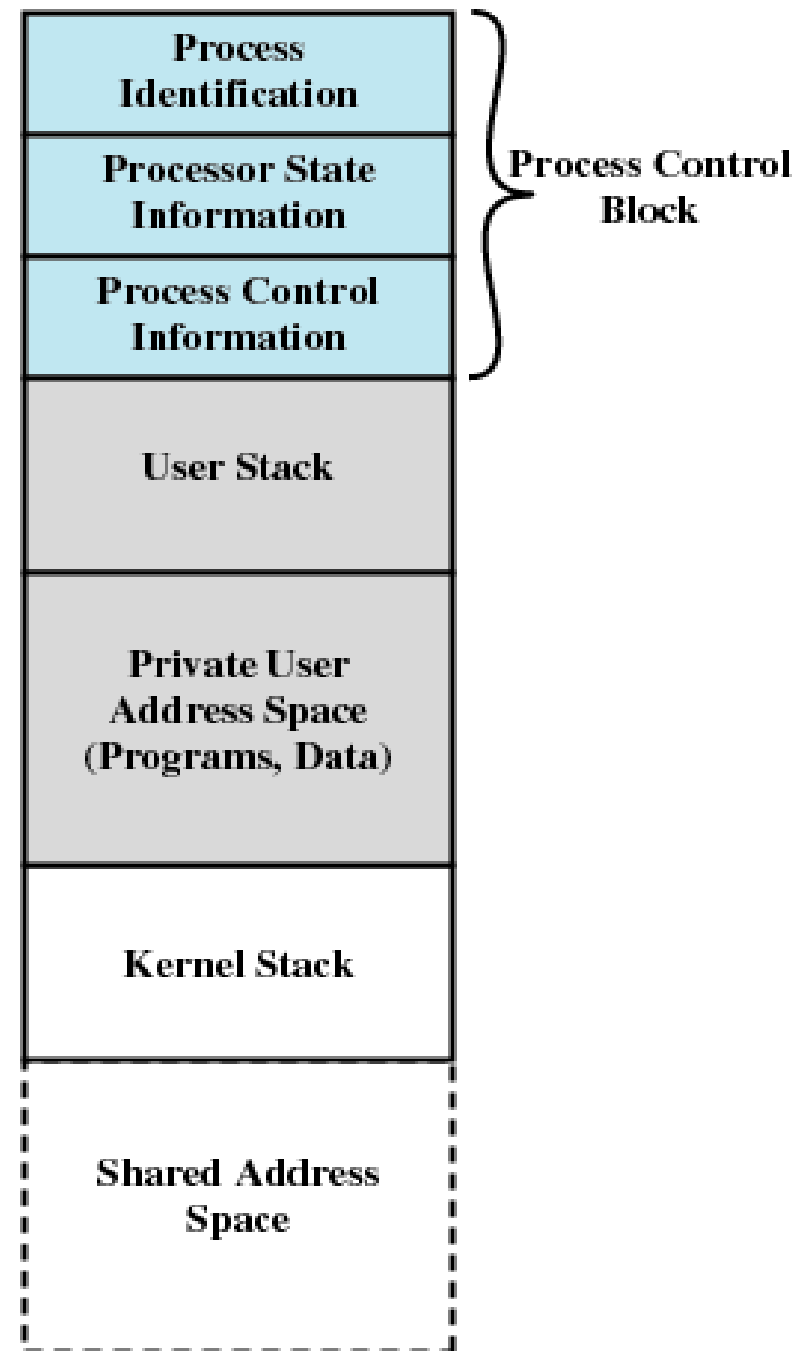

Execution Within User Processes

- to fulfill a system call or interrupt...
 - mode is switched
 - process is not switched
 - current memory image remain the same
 - both kernel data and current process data can be accessed
- a process switch occurs if and only if a new process is scheduled and dispatched
 - process switch is the only activity that can be considered outside of any process

process-based OS (microkernel)

- as “execution in user process” but kernel functionalities are minimal
 - thread/process scheduling and dispatching
 - Inter Process Communication (IPC)
 - direct access from os-processes to hardware
- Implement many os functionalities as a system process
 - system call are actually IPC messages
 - process switch and inter-process communication are the only activities that are outside of any process

process-based OS: design choices

- may processes run in kernel mode to access hardware?
- drivers are implemented in the kernel or as processes?
- consider the efficiency of the alternatives of an I/O operation
 - how many inter-processes messages?
 - how many mode switches?
 - how many process switches?
 - how many times dispatcher run?

process-based OS (microkernel)

- modular and robust
- flexible
 - services may be added, removed or distributed
- usually less efficient than “kernel execution within user process”
- Windows adopts this approach
 - in the sense that many functionalities are implemented as processes

real life OS

- unix BSD – monolithic “exec within user proc.”
- linux - hybrid approach
 - system is “executed within user process”
 - some OS tasks are demanded to special processes (kernel threads)
 - modular, efficient, not reliable as microkernel
- microkernels
 - mach, chorus, L4

real life OS: windows

- MS started with microkernel in mind
- not real a microkernel since NT4
 - kernel contains graphic code

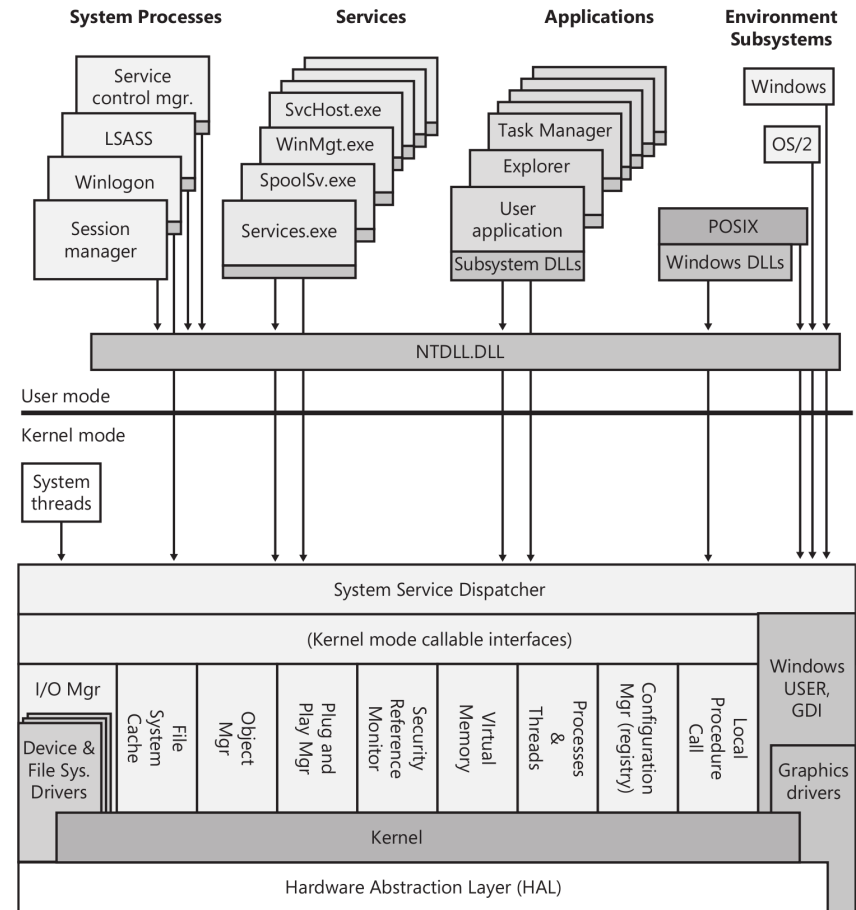

Hardware interfaces (buses, I/O devices, interrupts, interval timers, DMA, memory cache control, etc.)